

From the Morgan Oasis Garage

Cuthbert J. Twillie, Prop.

*Morgan Oasis Garage
Hoodsport, Washington
First Morgan Shop on
the Olympic Peninsula*

Recently I had to adjust the toe-in on a '62 Morgan Plus Four. The same car that had the bent front sub-frame. When the sub-frame was straightened the toe-in was way, way off.

In one of Ken Hill's trilogies he describes a method of measuring toe-in using a plumb-bob. It involves finding the center of both front tires, fore and aft. From the tire center a plumb-bob is dropped to make a mark on the floor in four places: left and right, fore and aft, of the front tires. From these marks one is asked to find one-eighth toe in at the wheel rim.

If you start out at the tread centers, how do you find an eighth inch at the rim?

Would it not be simpler to measure at the rim than to interpret the measurement from the tread?

The following method will absobloodylutely find the rim measurements and transfer them to the floor so they can tell you how much to adjust.

A steel framing square, a nail set, a sharp pencil, a tape rule, and a toll of masking tape are the only tools required.

The car is on the clean garage floor with the wheels pointing straight ahead. Place the short side of the square on the floor in front of a wheel with the long side along the wheel at the most forward point. Now find the wheel center. This was 13 1/2" on his car. At 13 1/2" from the floor the nail set is taped to the long side of the square. The square is moved to the wheel rim at the most foreword point. Directly below this point a mark is made on masking tape stuck at the appropriate position so a mark can be made at the edge of the square on the floor. If this is done on both wheels, fore and aft, there will be four marks on the floor that will tell you what the toe-in measures. It is supposed to be one eighth of an inch at the rim on a Morgan. The front measurement would be an eighth of an inch less than the rear measurement.

Now we are concerned with the toe-in adjustment. On a Mog this ought to be done when the kingpins are rebushed. For the life of me, I can't see it changes much on the rebuild, but how many rebuilds has your Mog had?

Since you now know what the toe-in is, what do you do? Tire stores and front end shops do this every day. They call it a "three way alignment." On a Mog the caster and camber are "built in" and cannot be adjusted so you don't need a three way. In the next epistle the adjustment will be explained.

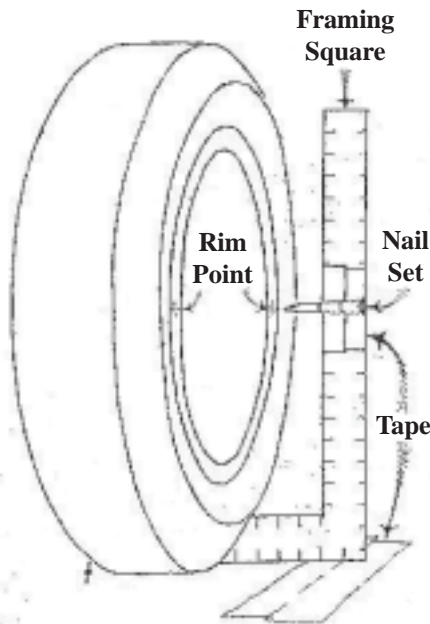

Members and Their Cars: The Statistics

Craig Runions

Number of vehicles by model				Number of vehicles per member		
model	2-seat	4-seat	totals	# owned	"exactly"	"or more"
4/4	40	8	48	6	1	1
+4	43	27	69	5	1	2
SS	5	1	6	4	2	4
DHC	15		16	3	5	9
+8	44		44	2	14	23
Aero 8	2		2	1	133	156
V6 Rdstr	2		2		subtotal	156
Trike	8		8	0	9	0
totals	159	36	195	totals	165	195

New MOGNW

Members

Craig Runions

There are fourteen new members in the March 2006 roster that aren't in the April 2005 roster:

ALBERTA

Don Mackay, Calgary, AB, '69 +8

BRITISH COLUMBIA

Dave Ashley, Vancouver, BC, '69 4/4

Heidi Marshall, Port Coquitlam, BC, '85 4/4

James Theroux, Surrey, BC, '68 4/4

Martin Zazvorka, Burnaby, BC, '58 +4 (renewal)

OREGON

Pierre Brun, Salem, OR, restoration/repair

Tom Woods, Beaverton, OR

COLORADO

Dave McEwen, Franktown, CO, '93 +8

GEORGIA

Sam Sellers, Alpharetta, GA, '05 Aero 8

WASHINGTON

Brooke Barnes, Seattle, WA, '50 4/4, '71 +8, '78 +8, '86 +8 (renewal)

Steve Bell, Des Moines, WA, '79 4/4

Doug Ellis, Orcas Island, WA, '94 +8

Joe Harley, Everett, WA

Jim Moran, Everett, WA, '67 +4

There are three new members, so new that they aren't in the 2006 roster:

BRITISH COLUMBIA

Peter Rossiter, RR4, 478B Pratt Road, Gibsons, BC V0N 1V4, (604) 740-1875, '60 +4

OREGON

John Forehand, 1009 NE Territorial Road, Canby, OR 97013, (503) 266-1415, '60 +4

WASHINGTON

Dave & Martha MacNeil, 2239 - 20th St., Clarkston, WA 99403, (509) 751-9703, dmmacneil@cableone.net, '59 +4

Current membership totals:

ALBERTA: 4
BRITISH COLUMBIA: 61
CALIFORNIA: 1
COLORADO: 2
GEORGIA: 1
IDAHO: 6
MASSACHUSETTS: 1
MAINE: 1
MONTANA: 1
NEW JERSEY: 1
OREGON: 26
WASHINGTON 59